



# Sewage Pump

**1/2 HP**

## Energy Efficient

- High performance PSC motor uses fewer amps than most shaded pole motors

## Industrial Strength

- Industrial-grade pump provides years of strong, dependable service

## Quiet Operation

[www.basementwatchdog.com](http://www.basementwatchdog.com)

*Watching Out for You!*



Model No.  
SW-50T

Pumping Capacity

**6000 GPH**

4400 GPH at 10' lift

Pump Construction

**Cast Iron/  
Stainless Steel**

**Tether  
Switch**



# Sewage Pump

## Pump Highlights

### Energy Efficient Permanent Split Capacitor (PSC) Motor

- Save money when using a Basement Watchdog pump



### Tether Float Switch

- Adjustable

### Premium Components Equals Durable Construction

- Cast iron / Stainless steel construction

### Strong Pumping Capacity

- 6000 GPH (gallons per hour) at 0' lift
- 4400 GPH at 10' lift

## Specifications

Motor HP	1/2 HP
GPH @ 0 ft	6,000
GPH @ 10 ft	4,400
Discharge	2.0" / 5.1 cm
Amps @ 10'	6.6
Line Voltage	115 VAC, 60 Hz
Power Cord Length	10 ft.
Weight	36.0 lbs / 16.3 kg
Width	8.125" / 20.6 cm
Depth	5.9" / 14.9 cm
Height	19.0" / 48.3 cm
Warranty	3 years

## Features

- 1 Permanent split capacitor motor increases energy efficiency
- 2 Dual seal protects the motor from unwanted water
- 3 Upper & lower ball bearings make for quiet operation and extend the life of the motor
- 4 Water cooled; no cooling oil to leak into the water system
- 5 Cast iron / Stainless steel construction for durability
- 6 2" Inlet and discharge
- 7 Non-corroding stainless steel hardware

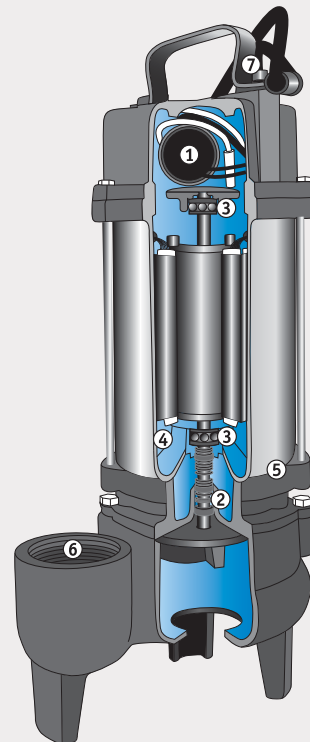

For additional information, go to:  
[www.BasementWatchdog.com/videos](http://www.BasementWatchdog.com/videos)

[www.basementwatchdog.com](http://www.basementwatchdog.com)

*Watching Out for You!*

