



Primary A/C Sump Pump

1/3 HP

Energy Efficient

- High performance PSC motor uses fewer amps than most shaded pole motors

Quiet Operation



Model No.
SP-33T

www.basementwatchdog.com

Watching Out for You!

Pumping Capacity

3700 GPH

2800 GPH at 10' lift

Pump Construction

Thermoplastic

**Tether
Switch**



Primary A/C Sump Pump

Pump Highlights

Energy Efficient Permanent Split Capacitor (PSC) Motor

- Save money when using a Basement Watchdog pump



Tether Float Switch

- Adjustable

Strong Pumping Capacity

- 3700 GPH (gallons per hour) at 0' lift
- 2800 GPH at 10' lift

Premium Components Equals Durable Construction

- Quiet operation

Specifications

Motor HP	1/3 HP
GPH @ 0 ft	3,700
GPH @ 10 ft	2,800
Discharge	1.5" / 3.8 cm
Amps @ 10'	4.2
Line Voltage	115 VAC, 60 Hz
Power Cord Length	10 ft.
Weight	12.5 lbs / 5.7 kg
Width	8.5" / 21.6 cm
Depth	7.75" / 19.7cm
Height	11.5" / 29.2 cm
Warranty	1 year

Features

- 1 Permanent split capacitor motor increases energy efficiency
- 2 Carbon ceramic seal protects the motor from unwanted water
- 3 Upper & lower ball bearings make for quiet operation and extend the life of the motor
- 4 1-1/2" Inlet and discharge
- 5 Non-corroding stainless steel hardware

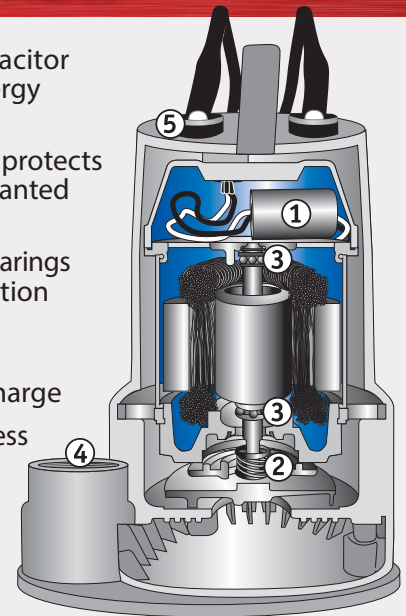

Consider a Backup

For added security and peace of mind, consider a Basement Watchdog Battery Backup Sump Pump System



www.basementwatchdog.com

Watching Out for You!

