

# Basement Watchdog Sump Pumps Instruction Manual & Safety Warnings



## Important Safety Instructions

**SAVE THESE INSTRUCTIONS.** This manual contains important SAFETY WARNINGS and OPERATING INSTRUCTIONS for the Basement Watchdog pumps. You will need to refer to it before attempting any installation or maintenance.  
**ALWAYS** keep these instructions with the unit so that they will be easily accessible. Failure to read and follow these warnings and instructions could result in property damage, serious injury, or death.

**⚠ WARNING** Risk of electric shock. To reduce this risk, observe the following precautions.

- **ALWAYS** disconnect the pump from the power source before servicing or making adjustments.
- **NEVER** handle the pump or motor with wet hands or when standing on a wet or damp surface while the pump is plugged into the power source.
- **MAKE SURE THERE IS A PROPERLY GROUNDED RECEPTACLE AVAILABLE.** This pump is wired with a 3-prong grounded plug. To reduce the risk of electric shock, be certain that it is only connected to a properly grounded, 3-prong receptacle (preferably with ground fault circuit interrupt). If you have a 2-prong receptacle, have a licensed electrician replace it with a 3-prong receptacle according to local codes and ordinances.
- **NEVER** bypass grounding wires or remove the ground prong from the plug.
- **DO NOT** use an extension cord. The electrical outlet should be within the length of the pump's power cord, and at least 4 feet above the floor level to minimize potential hazards from flood conditions.
- **DO** protect the electrical cord from sharp objects, hot surfaces, oil, and chemicals. Avoid kinking the cord.
- **MAKE SURE** the supply circuit has a fuse or circuit breaker rated to handle the power requirements noted on the nameplate of the pump.

**⚠ CAUTION** To reduce the risk of hazards that can cause injury or property damage, observe the following precautions.

- **DO NOT** use the power cord or strain relief to carry the pump. Use the pump handle.
- **DO NOT** expose the control unit to rain or snow.
- **DO NOT** operate the pump or control unit if it has been damaged in any way.
- **DO NOT** use sump pumps in pits handling raw sewage, salt water, or hazardous liquids.
- **DO NOT** disassemble the pump or control unit. When service is required, contact Glentronics technical support at 800-991-0466, option 3. Return the product to the manufacturer for any repairs at the following address:

**Glentronics, Inc.**  
640 Heathrow Drive, Lincolnshire, IL 60069

Specifications	1/3 HP Model BW1033	1/2 HP Model BW1050
GPH @ 0'	3200	4000
GPH @ 10'	2200	2820
Pump diameter	6.2"	6.2"
Volts	115V, 60Hz	115V, 60Hz

### Items Included:

- Pump
- Dual float and controller
- Stainless steel hose clamp



**1/3 HP Pump**  
BW1033



**1/2 HP Pump**  
BW1050



**The Dual Float  
& Controller**

### You may also need:

- A 1-1/2" PVC pipe adapter to screw into the discharge hole on top of the pump
- 1-1/2" rigid PVC pipe to connect to the existing plumbing
- A check valve or rubber union
- PVC pipe cleaner and cement
- Wire ties or hose clamps

## NOTICES

- The control unit must receive 115V AC +/- 5% and 60 Hz from the AC outlet.
- These primary pumps will not provide protection during a power outage. With the risk of property damage from high water levels, the addition of a Basement Watchdog battery backup sump pump system is highly recommended.
- After the initial installation, be sure to check the operation by filling the sump with water and observing the pump operation through one full cycle.
- For continuous duty operation, the pump must be submerged at least 3/4 of the depth of the pump at all times.
- In instances where the discharge line is exposed to freezing temperatures, the pipe must be sloped downward so any remaining water will drain out. Failure to do so will prevent water from exiting the sump and damage the pump if the line freezes.

## Installation Instructions

### Prior to Installation

1. Visually inspect your pump. Products may be damaged during shipping. If the product has been damaged, contact your place of purchase or Glentronics, Inc. before installation.
2. Thoroughly read the instructions provided to learn specific details regarding installation and use. This manual should be retained for future reference.

### ⚠ WARNING

This installation must be in accordance with the National Electric Code and all applicable local codes and ordinances.

1. Use a pit that conforms to all local codes and is large enough to accommodate the pump and float switch. The minimum requirements for pumps with the double float assembly are 7" in diameter and 14" deep. However, larger sump pits are preferred, since they will extend the discharge cycle and reduce the number of times the pump turns on.
2. Clean the pit of all debris. The pump's strainer must be kept clear.
3. The pump should not be set directly onto a clay, earthen, or sand base. You may install bricks or blocks under the pump to provide a solid base.
4. The pump should be level.
5. Install discharge plumbing according to local, regional and state codes. Rigid PVC pipe is recommended.
6. An in-line check valve is recommended to prevent back-flow. This check valve is mandatory when sharing a discharge line with another pump (i.e. a back-up pump or a second primary pump).
7. Install a gate valve or ball valve if required by any codes.
8. In instances where the discharge line is exposed to freezing temperatures, the pipe must be positioned in a downward slope so any remaining water will drain away. Failure to do this will prevent water from exiting the pit and damage the pump if the line freezes.
9. If you are replacing an old sump pump:
  - (a) Unplug the pump from the outlet.
  - (b) Loosen the check valve or rubber union by unscrewing the bottom hose clamp. (If the existing system is installed without a check valve or rubber union, saw the pipe apart above the sump pit.)
  - (c) Remove the old pump and unscrew the pipe and adapter.

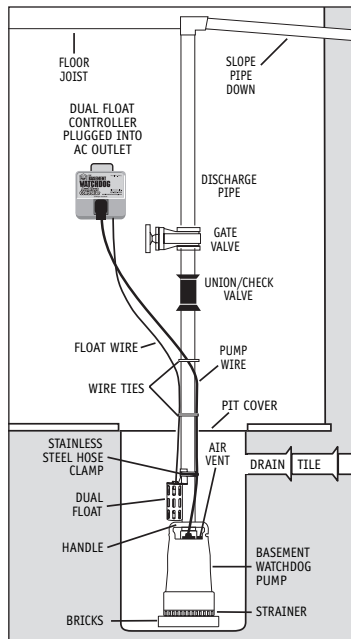

- (d) If the adapter fits into the new pump, screw the pipe into the pump. If not, cut a piece of rigid PVC pipe and connect it to a 1-1/2" PVC adapter by cementing the two pieces together. (Follow the instructions on the PVC cleaner and cement.) Then screw the new piece into the pump.
- (e) Loosen the enclosed stainless steel hose clamp by turning the screw counterclockwise and slip it over the pipe on top of the pump.
- (f) Hold the float switch against the discharge pipe so the cage is below the bracket.
- (g) Position the bottom of the float at the height you want the pump to activate and turn the screw clockwise to tighten the hose clamp, but do not tighten it completely at this time.
- (h) Lower the pump into the sump by the handle.
- (i) To avoid debris pouring into the float, it should be positioned on the side of the discharge pipe opposite the drain tile. Note: It is desirable to mount the float below the drain tile that empties into the pit. Mounting it above the drain tile would allow water to fill the drain tile before the pump is activated. (See diagram.)
- (j) Once the switch is in the desired position, tighten the hose clamp.
- (k) Connect the pipe on the pump to the existing discharge pipe with a rubber union or check valve and tighten the hose clamps securely.

## Connecting the Pump and Controller

### ⚠ WARNING

Make sure the outlet is single phase, 115V and 60HZ for all the pump installations.

### Dual Float Controller

Plug the control box into a properly grounded, 3-prong receptacle (preferably with ground fault circuit interrupt), then insert the pump plug into the receptacle on the control box.

For a neater installation, secure the power cord and the float switch cord to the discharge pipe with wire ties or hose clamps. Keep the cords separated from each other on opposite sides of the pipe.

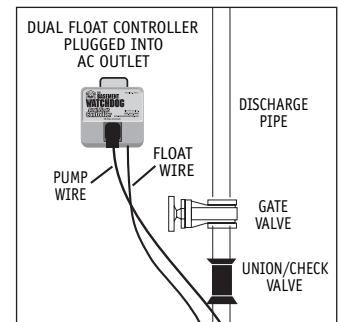

### Completing the Installation

1. After the initial installation, be sure to check the pump operation by filling the sump with water and observing the pump through one full cycle. The pump should run for 10 seconds after the lower float drops. Note: When the pump activates, it should have a "normal pumping" sound. Any abnormal sound, vibration, or lack of output is the signal of a problem. Stop the pump and refer to the troubleshooting guide.
2. Replace the pit cover making sure not to pinch or crimp the pump wire with the cover. The pit cover either has a 'hole punch' that will allow the cord to be passed through or one can be drilled.

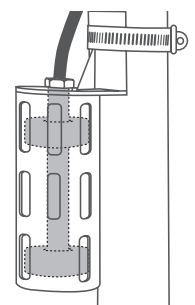

## Product Operation

### Dual Float Switch

The dual float switch contains two large floating rings enclosed within a protective cage. Water will lift the bottom float by a 1/4", which will activate the pump. If for any reason the lower float does not activate the pump, the water will rise and activate the second switch. As the

pump evacuates the water from the pit the floats will drop. The pump will run for an additional 10 seconds to extend the cycle after the lower float drops. *Note: When mounting the float switch, position the bottom of the cage at the height you want the pump to activate.*

**Dual Float Controller**

This control box contains a piggyback switch that powers the Basement Watchdog Dual Float. The Dual Float Controller will activate the pump when either float is lifted, and then shuts off automatically 10 seconds after the float drops.



**Operating the Pump in a Continuous Duty Application**

The Basement Watchdog pumps are rated for continuous duty and may be used in applications requiring continuous pumping including fountains, ponds, etc. For use in any continuous duty application the pump should be plugged directly into the wall outlet without the use of the controller. The outlet must be a single phase properly grounded 3-prong receptacle, 115V, 60HZ (preferably with ground fault circuit interrupt). *For continuous duty operation, the pump must be submerged at least 3/4 of the depth of the pump at all times.*

**Maintenance Check List**

Maintenance should be performed 1-2 times per year.

1. Remove all debris from the bottom of the pit.
2. Remove all debris floating in the water.
3. Remove all debris from the float switch cage.
4. Fill the pit with water. Make sure pump turns on at the intended level.
5. While the pump is running, make sure pump is evacuating water at a good pace.

Visit our website [www.basementwatchdog.com](http://www.basementwatchdog.com) for more information about the Basement Watchdog AC sump pumps and battery backup sump pump products.

**Backup Installation**

When the power goes out, the Basement Watchdog AC sump pumps will not operate. For protection during a power outage, a Basement Watchdog battery backup system can be installed. There are three systems with matching batteries that will provide protection. The illustration below is an example of a typical battery backup installation.

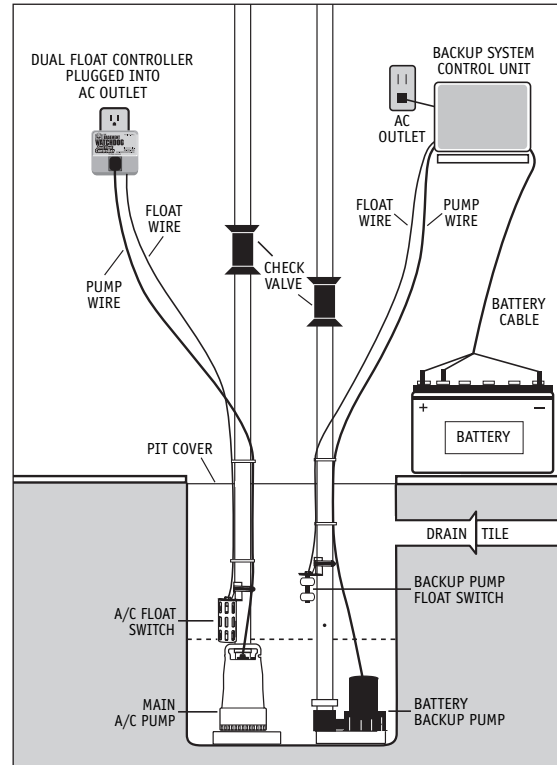

**Warranty**

GLENTRONICS, INC. warrants to the end purchaser that its pumps, switch and control unit products are free from defective materials and workmanship for the periods indicated below: All parts and labor (excluding installation) for a period of:

- 3 years from the date of purchase, when used intermittently as a sump pump
- 1 year from the date of purchase, when used in continuous duty operations such as fountains or ponds

The defective product must be returned directly to the factory, postage prepaid with the original bill of sale or receipt to the address listed below. GLENTRONICS, INC., at its option, will either repair or replace the product and return it postage prepaid.

**Conditions**

The unit must be shipped, freight prepaid, or delivered to GLENTRONICS, INC. to provide the services described hereunder in either its original carton and inserts, or a similar package affording an equal degree of protection.

The unit must not have been previously altered, repaired or serviced by anyone other than GLENTRONICS, INC., or its agent; the serial number on the unit must not have been altered or removed; the unit must not have been subject to accident, misuse, abuse or operated contrary to the instructions contained in the accompanying manual.

The dealer's dated bill of sale, or installers invoice must be retained as evidence of the date of purchase and to establish warranty eligibility.

This warranty does not cover product problems resulting from handling liquids hotter than 104 degrees Fahrenheit, handling inflammable liquids, solvents, strong chemicals or severe abrasive solutions; user abuse; misuse, neglect, improper maintenance, commercial or industrial use; improper connection or installation, damages caused by lightning strikes; excessive surges in AC line voltage; water damage to the controller; or failure to operate in accordance with the enclosed written instructions.

GLENTRONICS, INC. WILL NOT BE LIABLE FOR ANY INCIDENTAL, SPECIAL OR CONSEQUENTIAL DAMAGES FOR BREACH OF ANY EXPRESS OR IMPLIED WARRANTIES ON THIS PRODUCT. SOME STATES DO NOT ALLOW FOR THE EXCLUSION OR LIMITATION OF CONSEQUENTIAL OR INDIRECT DAMAGE. THE ABOVE LIMITATION MAY NOT APPLY TO YOU. THIS EXPRESS WARRANTY SHALL BE EXCLUSIVE AND IS IN LIEU OF ALL OTHER WARRANTIES, WRITTEN OR ORAL, EXPRESS OR IMPLIED, INCLUDING, BUT NOT LIMITED TO ANY WARRANTY OF MERCHANTABILITY OR FITNESS FOR A PARTICULAR PURPOSE. THIS CUSTOMER'S EXCLUSIVE REMEDY FOR BREACH OF THIS WARRANTY, OR OF ANY IMPLIED WARRANTY NOT EXCLUDED HEREIN, SHALL BE LIMITED TO REPAIR OR REPLACEMENT OF THE PRODUCT.

**For information or service contact:**

Glentronics, Inc., 640 Heathrow Drive, Lincolnshire, IL 60069 800-991-0466

Model No. \_\_\_\_\_

Purchase Date \_\_\_\_\_

## Troubleshooting

The pump will not start or run	Pump is not plugged in	Plug pump in properly (see instructions)
	Water is not high enough to activate the pump	Make sure float switch is positioned properly
	No AC power	Check circuit breaker or fuse, and GFI reset button
	Poor power source	Check circuit line wires and cable*
	Low voltage	Check line wires and source voltage*
	Locked impeller	Remove strainer and clear obstruction
	Defective float switch	Replace float switch with new float switch
Thermal protector tripping or not functioning	Defective pump	Replace pump with new pump
	Locked impeller	Remove strainer and clear obstruction
	Incorrect power supply	Check power supply source and voltage
	Overburdened due to heavy sand content in the water	Use water filter or replace with a higher wattage pump
Pump starts and stops too frequently	Pump running continuously with no water present	Check float switch
	Float switch mounted too low	Raise float switch
	Water flowing back from pipe	Install or replace check valve
Pump will not shut off	Malfunctioning float switch	Replace float switch with new float switch
	Clogged or frozen discharge	Clear blockage or thaw frozen line
	Blocked intake strainer	Clear debris from intake strainer
	One or both of the floats is obstructed and cannot drop down	Clear debris from inside the float cage (Loosen nut on top of float, then remove c-clip on bottom of float. Remove debris. Tighten nut on top of float, then replace c-clip on bottom of float.) When reassembling the float, the magnetic strip on the inside of the float should be facing down.
	Defective float switch	Replace float switch with new float switch
Insufficient or no water volume	Check valve is stuck or installed upside down	Reverse or replace check valve. Make sure the check valve is installed with the flow arrow pointing up and out of the pit.
	Check valve on secondary pump will not close and water re-circulates within the system	Replace the check valve on the secondary pump
	Partially blocked impeller	Remove strainer and clear obstruction
	Clogged or frozen discharge pipe	Clear blockage or thaw frozen line
	Broken or leaking pipe	Repair piping
	Low power voltage	Check power voltage, wires and cable condition
Abnormal sound or vibration	Check valve is stuck or installed upside down	Reverse or replace the check valve. Be sure check valve is installed with flow arrow pointing up and out of the pit
	Check valve on secondary pump will not close and water re-circulates within the system	Replace the check valve on the secondary pump
	Blocked intake screen	Clear debris from intake screen