



Primary A/C Sump Pump

1/2 HP

Energy Efficient

- High performance PSC motor uses fewer amps than most shaded pole motors

Dual Float Switch

- Caged dual float for added reliability

Industrial Strength

- Industrial-grade pump provides years of strong, dependable service

Model No.
BWT050



www.basementwatchdog.com

Watching Out for You!

Pumping Capacity

4100 GPH

2770 GPH at 10' lift

Pump Construction

**Cast Iron/
Cast Aluminum**

**Dual Float
Switch**



Primary A/C Sump Pump

Pump Highlights

Energy Efficient Permanent Split Capacitor (PSC) Motor

- Save money when using a Basement Watchdog pump



Caged Dual Float

- Double the protection for added reliability
- Protective cage prevents debris or wires from interfering with float operation

Premium Components Equals Durable Construction

- Cast iron/cast aluminum construction

Strong Pumping Capacity

- 3720 GPH (gallons per hour) at 0' lift
- 3100 GPH at 10' lift

Specifications

Motor HP	1/2 HP
GPH @ 0 ft	4,100
GPH @ 10 ft	2,770
Discharge	1.5" / 3.8 cm
Amps @ 10'	3.8
Line Voltage	115 VAC, 60 Hz
Power Cord Length	10 ft.
Weight	17 lbs / 7.7 kg
Width	7.5" / 19 cm
Depth	5" / 12.7 cm
Height	13.75" / 34.9 cm
Warranty	3 years

Features

- 1 Permanent split capacitor motor increases energy efficiency
- 2 Heavy duty cast iron/cast aluminum housing
- 3 Will fit in 10" diameter sump pit
- 4 Electroplated steel shaft
- 5 Upper and lower sealed ball bearings
- 6 Water-cooled
- 7 Thermally protected
- 8 Two carbon ceramic shaft seals
- 9 1½" outlet for higher capacity (BWT050)
2" outlet for higher capacity (BWT075)
- 10 Engineered Polymer Impeller

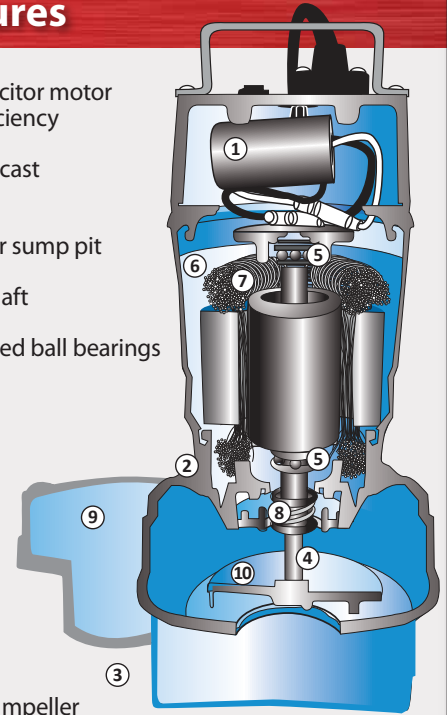

Consider a Backup

For added security and peace of mind, consider a Basement Watchdog Battery Backup Sump Pump System.



www.basementwatchdog.com

Watching Out for You!

